



PFR140 120 80 60

- Microprocessor based intelligent auto switching control
- Automatic C/K and rated step adjustment
- Automatic CT polarity correction
- Display of power factor, current & total harmonic distortion of current
- Programmable sensitivity
- Last step can be used as alarm/fan output
- Under/over voltage alarm, under/over compensate alarm & high harmonic distortion alarm
- User-friendly setting
- Complies with IEC 61000-6-2 standard

Technical Data

RATINGS AUXILIARY POWER SUPPLY

Current Supply voltage	: 220~240 V AC / 380~415 V AC
Operating Limits	: -15% + 10%
Consumption	: 10 VA max
Rated frequency	: 50 Hz or 60 Hz

OUTPUT CONTACTS

Numbers of outputs	: 6 / 8 / 12 / 14 (PFR60/PFR80 /PFR120/PFR140)
Rated voltage	: 250 V AC
Contact rating	: 5 A
Expected electrical life	: 100,000 operations at rated current
Expected mechanical life	: 5 x 10 ⁶ operations
Max current for the common terminals	: 12 A continuous

CURRENT INPUT

Rated current (In)	: 5 A
Operating Limits	: 0.05 A to 6.5 A
Rated Frequency	: 50 Hz or 60 Hz

CONTROL RANGE

Power factor setting	: 0.8 Ind - 0.8 Cap
C/K setting	: 0.03 - 1.20 / Automatic
Switching sensitivity	: 5 - 600 s/step
Reconnection time for same step	: 5 - 240 s
THD threshold	: 0.20 - 3.00 (20% - 300%) / OFF
Switching Program	: Automatic / Automatic Rotate / 4-quadrant / Manual
Rated step coefficient	: 0 / 1 / 2 / 3 / 4 / 5 / 6 / 8 / 12 / 16 (Automatic if C/K set to Auto)

ENVIRONMENTAL CONDITIONS

Temperature	: -10°C to 55°C
Humidity	: 5% to 95%, non-condensing

MECHANICAL

Mounting	: Panel mounting
Dimension (mm)	: 144(w) x 144(h) x 90(d)
Enclosure protection	: IP54 at the panel
Approximate weight	: 1.2 kg

Typical Application Diagram

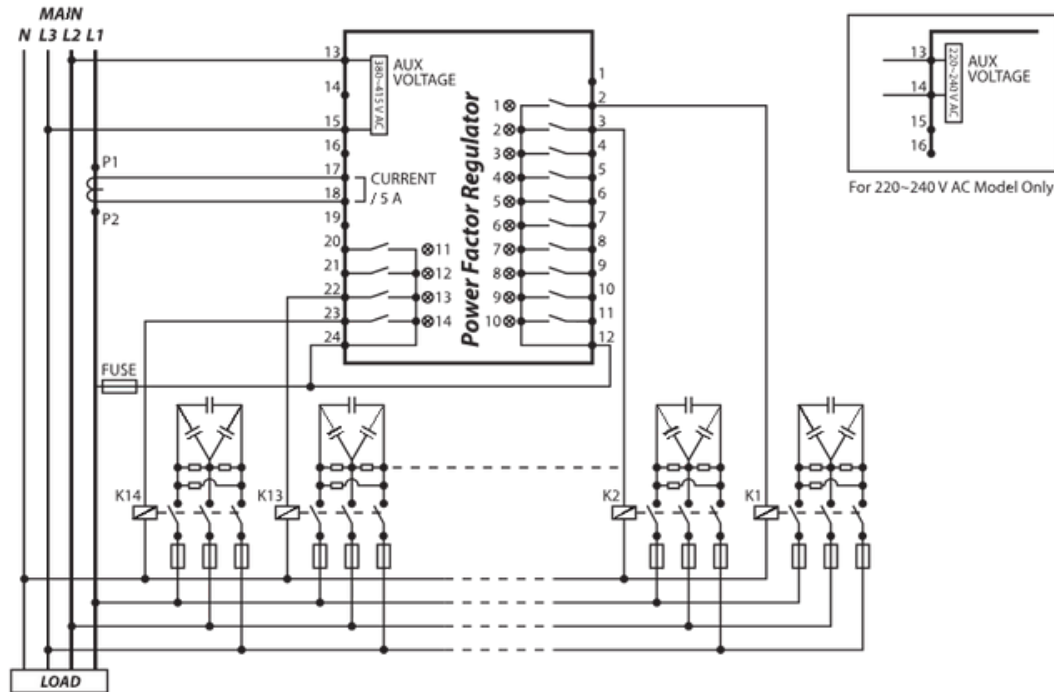

Case Dimensions

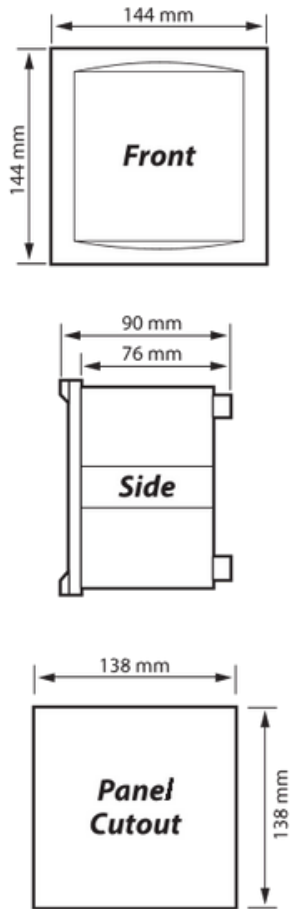

Ordering Information

MODEL	DESCRIPTION
PFR60 - 415 - 50	6 Steps, 50 Hz system, auxiliary voltage 380~415 V AC
PFR80 - 415 - 50	8 Steps, 50 Hz system, auxiliary voltage 380~415 V AC
PFR120 - 415 - 50	12 Steps, 50 Hz system, auxiliary voltage 380~415 V AC
PFR140 - 415 - 50	14 Steps, 50 Hz system, auxiliary voltage 380~415 V AC
PFR60 - 220 - 50	6 Steps, 50 Hz system, auxiliary voltage 220~240 V AC
PFR80 - 220 - 50	8 Steps, 50 Hz system, auxiliary voltage 220~240 V AC
PFR120 - 220 - 50	12 Steps, 50 Hz system, auxiliary voltage 220~240 V AC
PFR140 - 220 - 50	14 Steps, 50 Hz system, auxiliary voltage 220~240 V AC
PFR60 - 415 - 60	6 Steps, 60 Hz system, auxiliary voltage 380~415 V AC
PFR80 - 415 - 60	8 Steps, 60 Hz system, auxiliary voltage 380~415 V AC
PFR120 - 415 - 60	12 Steps, 60 Hz system, auxiliary voltage 380~415 V AC
PFR140 - 415 - 60	14 Steps, 60 Hz system, auxiliary voltage 380~415 V AC
PFR60 - 220 - 60	6 Steps, 60 Hz system, auxiliary voltage 220~240 V AC
PFR80 - 220 - 60	8 Steps, 60 Hz system, auxiliary voltage 220~240 V AC
PFR120 - 220 - 60	12 Steps, 60 Hz system, auxiliary voltage 220~240 V AC
PFR140 - 220 - 60	14 Steps, 60 Hz system, auxiliary voltage 220~240 V AC